

## Cylinder Regulator

# WegaMed

with two outlets

MEDI  
CAL

### Specification

Single stage cylinder pressure regulator according to DIN 738-1 for the pressure reduction of pressurised medical gases.

CE -mark according to the Medical Device Directive 93/42/EEC.

Fluid Media

med. O<sub>2</sub>, Air, N<sub>2</sub>O, CO<sub>2</sub>, Xe

Operating Parameters

Inlet pressure:

Air, O<sub>2</sub> ..... 11 to 200 bar /160 to 2900 PSIG

N<sub>2</sub>O, CO<sub>2</sub>, Xe .... 11 to 60 bar / 160 to 870 PSIG

Outlet Pressure:

Air ..... 5 bar / 73 PSIG

..... at nominal flow 55 l/min

O<sub>2</sub> ..... 5 bar / 73 PSIG

..... at nominal flow 50 l/min

N<sub>2</sub>O ..... 5 bar / 73 PSIG

..... at nominal flow 45 l/min

CO<sub>2</sub> ..... 5 bar / 73 PSIG

..... at nominal flow 45 l/min

Xe ..... 5 bar / 73 PSIG

..... at nominal flow 25 l/min

Relief valve:

Opening pressure ..... 8 bar / 116 PSIG

Min. Flow ..... 220 l/min (Air)

Temperature range:

Operation ..... 10 to 40 °C

Storage ..... -20 to +70 °C

Weight ..... ca. 1.2 kg (depending on inlet connection)

Connections ..... refer to order no. backpage



- Compact design
- Robust and reliable design for stationary and mobile application
- Integrated pressure relief valve

TESCOM  
EUROPE

# WegaMed with two outlets

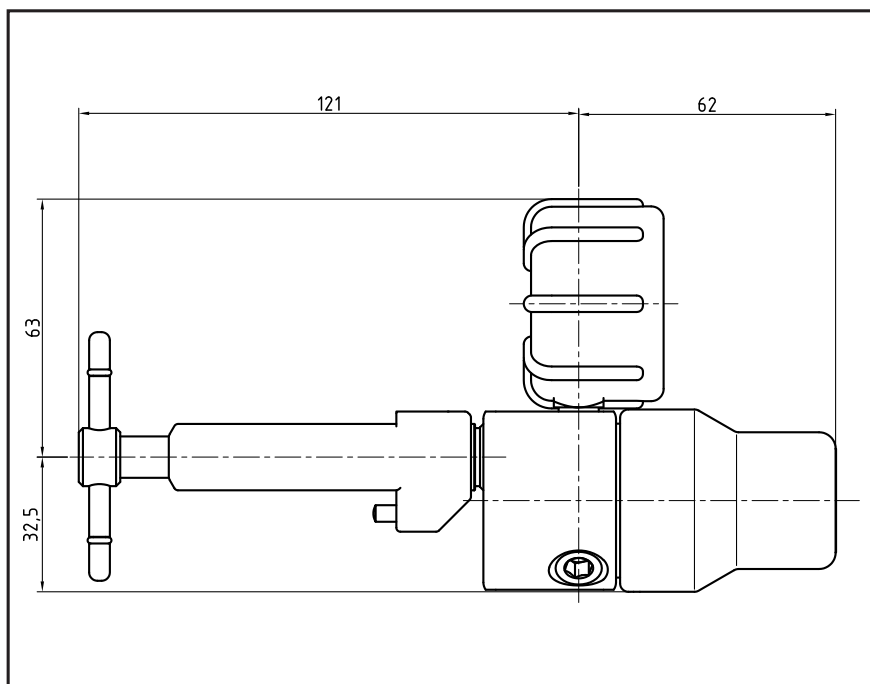

All dimensions in mm are approximate data depending on the design.



## Ordering Information

Example Part Number:

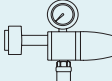
**D45668 - 12 E 00 2 D**

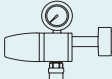
BASIC SERIES	GAS <sup>1)</sup>	INLET CONNECTION <sup>2)</sup>	OUTLET CONNECTION <sup>3)</sup>	GAUGE DIAMETER & CAP	GAUGE ORIENTATION
<b>D45668</b>	<b>03</b> = CO <sub>2</sub> <b>08</b> = Air <b>12</b> = O <sub>2</sub> <b>13</b> = N <sub>2</sub> O <b>46</b> = Xe	<b>E</b> = EN 850 Pin-Index	<b>00</b> = without (G 1/4 female)	<b>1</b> = ø 40 with safety cap  <b>2</b> = ø 40 without safety cap	<b>B</b> = at left side  <b>C</b> = at front side  <b>D</b> = at right side 

1) neutral gas code marking (other gas code marking on request)

2) further inlet connections on request

3) further outlet connections on request



An der Trave 23-25 • D-23923 Selmsdorf • Germany  
 Tel. +49/(0)38823/31-0 • Fax +49/(0)38823/31-199  
 info@tescom-europe.com • www.tescom-europe.com